

*Let's communicate*



**RS-232 / 485 Converter with Automatic Transmission  
Control and Galvanic Isolation of the Interface**



**ELO E06C**

**Operation manual**



<b>1.0</b>	<b><i>Introduction</i></b> .....	<b>4</b>
<b>1.1</b>	<b><i>Use of the converter</i></b> .....	<b>4</b>
<b>2.0</b>	<b><i>Operation principles</i></b> .....	<b>4</b>
<b>3.0</b>	<b><i>Installation</i></b> .....	<b>5</b>
<b>3.1</b>	<b><i>Converter connection to RS-232 Interface</i></b> .....	<b>5</b>
<b>3.2</b>	<b><i>RS-485 link connection</i></b> .....	<b>5</b>
<b>3.3</b>	<b><i>Converter setting</i></b> .....	<b>7</b>
<b>3.4</b>	<b><i>Power Supply Connection</i></b> .....	<b>8</b>
<b>4.0</b>	<b><i>Specifications</i></b> .....	<b>8</b>
<b>4.1</b>	<b><i>Electrical parameters</i></b> .....	<b>8</b>
<b>4.2</b>	<b><i>Other</i></b> .....	<b>8</b>
<b>5.0</b>	<b><i>Testing</i></b> .....	<b>8</b>
<b>6.0</b>	<b><i>Troubleshooting</i></b> .....	<b>9</b>
<b>7.0</b>	<b><i>Ordering information</i></b> .....	<b>9</b>

## 1.0 Introduction

RS-232 is the interface with asymmetric signals designed for two terminal equipments connection (DTE). The load impedance is to be 3-7 kilo-ohm that enables to induce disturbing pulses into the cable even from relatively soft supplies. Since the signals have to be symmetric, the terminal equipments have to have the same neutral potentials. For this reason, RS-232 interface range is limited to 15 m distance. Signals conversion to RS-485 enables to increase communication range, transmission interference immunity and communication partners' number.

### 1.1 Use of the converter

The converter increases transmission immunity against electrical disturbance and isolates both interfaces RS-232/RS-485. Insulation strength is 3 kV. As for permissible over-voltage, the converter is designed to be used in the environments where lightning over-voltage is not necessary to be considered. To lead the cable outside buildings, it is necessary to provide additional over-voltage protection on the input points.

The converter allows transmission rate up to 115200 bps. This maximum attainable rate decreases due to the line length and/or its impedance growth. Recommended maximum line length is 1200 m at the rate of 9600 bps.

## 2.0 Operation principles

RS-485 interface is used to two-way simultaneous communication in one pair of conductors. For this reason, the transmission has to be half-duplex that means switching off RS-485 transmitter when receiving to allow transmitting to other communication partners and switching on during its own transmitting only. The converter implies TE does not use RTS signal to control the transmitter. For this reason, the converter has to interpret its signal TxD **automatically**. At the TxD changing moment from the idle state (from the negative to positive polarity), the converter activates the link transmitter automatically.

**The transmitter is switched off after the certain time  $\tau$**  of TxD return to the neutral polarity. Time interval length  $\tau$  has to be matched to applied transmission rate because in the automatic mode there it is necessary to keep the transmitter active for the period equal to one byte transmission time. One important communication protocol request is necessary to observe: a device that is to transmit has to wait at least for the time  $\tau$  from the last byte recorded on RS-485 clamps. If it is to the contrary the first transmitted byte would be damaged.

### 3.0 Installation

The converter has to be installed with the respect for specifications of both interfaces.

#### 3.1 Converter connection to RS-232 Interface

Signals assignment to the contacts and DTE DCE interconnection is in the following table:

Signal name	abbrev	DTE connector (DB25M)	connector E06C (DB25F)	trans.direction	
				DTE	E06C
Signal Ground	SG	7	7	--	--
Transmitted Data	TxD	2	2	output	input
Received Data	RxD	3	3	input	output
Request To Send	RTS	4	4	output	input
Clear To Send	CTS	5	5	input	output
Data Set Ready	DSR	6	6	input	output
Data Terminal Ready	DTR	20	20	output	input
Data Carrier Detect	DCD	8	8	input	output

ELO E06C transmits RxD and TxD signals. Control signals are not transmitted. The converter contains local interconnectors RTS-CTS and DTR-DST-DCD. Maximum transmission rate is 115200 bps.

**!!! Be careful of a frequent mistake !!!**  
**The same cable is often used for two DTE interconnection and DTE – DCE (converter) interconnection to follow. The cable DTE – DCE has to be connected 1:1.**

#### 3.2 RS-485 link connection

The DB25M (Male) connector is used to the link connection. Single DTE can be interconnected via bus (see Fig.) up to 32 partners.

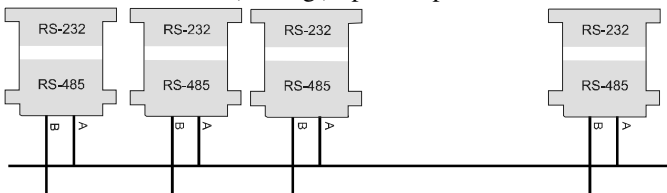

The RS-485 interface connector description and the way of the passive and active terminator connection (resistors values of the active terminator have to be calculated with reference to the applied values of passive terminators so that the passive terminator voltage drop was 200 mV):

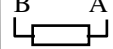
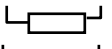
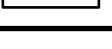
contact	1	2	5-8	13	25	10	11	
signal	B	A	GND	GND	12V	rate	$\tau 1$	$\tau 2$
passive terminator	 120 $\Omega$					9 600	open contacts	
						19 200	39k	
						115 200		

The RS-485 line should be terminated with the 100-120  $\Omega$  resistors on both ends placed between A - B conductors (so-called passive terminators). These terminators are used for the converter impedance matching, undesirable echo suppression and they influence transfer immunity against interference. There are also the active terminators beside the passive ones. Only one active terminator can be installed to one metallic section of the link and its role is as follows:

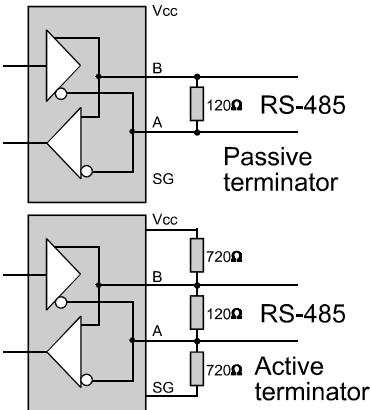

The RS-485 signal is symmetric. The differential receiver interprets the difference  $U_A - U_B$ . It does not depend on the signal ground potential. The receiver interprets the obtained signal  $|U_A - U_B| > 200 \text{ mV}$  as log. 1 or log. 0.

In addition to these levels the third state can occur, it is so-called IDLE state. No transmitter is activated, each communicating partner is just listening so  $|U_A - U_B| < 200 \text{ mV}$ . The problem is how to interpret the third state in the two-state logic. The active terminator gives the signal into the IDLE state line and it is

interpreted as IDLE in the two-state logic.

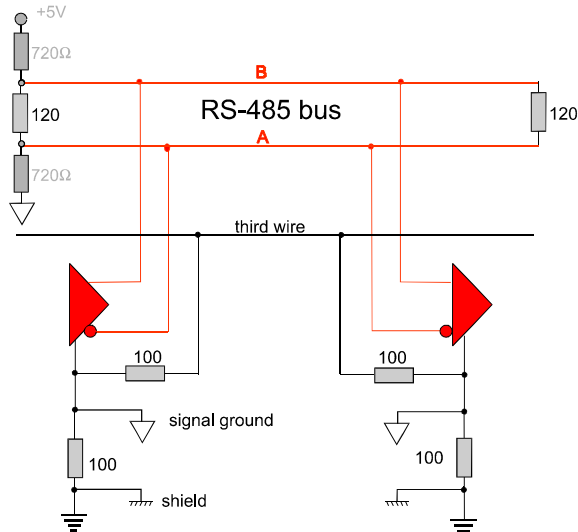

When using terminators with E06C model, supply take off increase is necessary to consider carefully, it should not exceed c. 80 mA.

To eliminate influence of the ground potentials differences, each device is earthed on the neutral or the third conductor is used (see Fig.). 100  $\Omega$  resistors are needed in this case to eliminate currents resulting from the ground potentials differences.

### 3.3 Converter setting

To work properly, the converter needs time out setting  $\tau$  which is performed by 10 and 11 contacts jumpers of the RS-485 connector.

mode	rate	contacts
A U T	9 600	10 and 11 uncoupled
M A T	19 200	10 and 11 interconnected via 39 k $\Omega$ resistor
	38 400	10 and 11 interconnected via 20 k $\Omega$ resistor
	115 200	10 and 11 connected

### 3.4 Power Supply Connection

The converter needs external 12V/80 mA power supply connected via 25 (positive terminal) and 6, 7 or 8 (negative terminal) contacts of RS-485 connector. If there is a passive terminator on the link the on-peak take off is increased roughly by the current passing this terminator.

## 4.0 Specifications

### 4.1 Electrical parameters

Interface	RS-232/RS-422
Transmitted signals	TxD and RxD
Control signals	local interconnectors RTS-CTS DTR-DSR-DCD
RS-232 connector	DB25F, DCE
Transmission mode	half-duplex
Power supply	external DC supply 12V/80mA
Isolation voltage between interfaces	3 kV
Permissible over-voltage on the line under ČSN 33 0420:	the line must not be exposed to the atmospheric discharge influences
Required link impedance	100Ω
Signals take off:	
TxD, (DTR, RTS) summarily	max. 6mA, typically 3mA

### 4.2 Other

Range without repeaters	1200m, double-wire link
Maximum data rate	115 200 bps
Minimum data rate	9 600 bps
Dimension: width x length x height	57 x 83 x 24 mm
Weight	80 g
Stocking temperature	- 10° to +55° C
Working temperature	+ 0° to +50° C
Humidity	0 – 85% (non-condensing)

## 5.0 Testing

When the power supply is switched on, connect positive terminal to the 2 contact and negative terminal to the 7 contact of the DC power supply of 5 to 9 V on the RS-232 connector. The voltage of c. 3V has to be on the 1-2 contacts of the RS-485

connector. After reversing polarity 2-7 contacts, 1-2 output voltage has to decrease to zero.

## 6.0 Troubleshooting

Symptom	Action
Converter does not work after installation	Check if the link is connected properly, if 1-2 contacts are not changed. Check if the time constant selection is right. Check the power supply. Check RS-232 connection.
Connection in normal operation quit working	Check the power supply. Check the cable connection. Use the test as with 5.0

## 7.0 Ordering information

Supply code is ELO E06C.

Note

---



