

*Let's communicate*



**Asynchronous RS-232/485 Converter with Automatic  
Transmission Control and Galvanic Isolation of the  
Interface**



**ELO E069**

**Operation manual**



<b>1.0</b>	<b><i>Introduction</i></b>	<b>4</b>
<b>1.1</b>	<b><i>Use of the converter</i></b>	<b>4</b>
<b>2.0</b>	<b><i>Operation principles</i></b>	<b>4</b>
<b>3.0</b>	<b><i>Installation</i></b>	<b>5</b>
<b>3.1</b>	<b><i>Converter connection to RS-232 Interface</i></b>	<b>5</b>
<b>3.2</b>	<b><i>RS-485 link connection</i></b>	<b>6</b>
<b>3.3</b>	<b><i>Converter setting</i></b>	<b>8</b>
<b>3.4</b>	<b><i>Power Supply Connection</i></b>	<b>8</b>
<b>4.0</b>	<b><i>Specifications</i></b>	<b>8</b>
<b>4.1</b>	<b><i>Electrical parameters</i></b>	<b>8</b>
<b>4.2</b>	<b><i>Other</i></b>	<b>9</b>
<b>5.0</b>	<b><i>Testing</i></b>	<b>9</b>
<b>6.0</b>	<b><i>Troubleshooting</i></b>	<b>9</b>
<b>7.0</b>	<b><i>Ordering information</i></b>	<b>10</b>

## 1.0 Introduction

RS-232 interface with asymmetric signals is designed for two terminal equipments connection (DTE). Maximum load capacity can be 2500 pF (about 50m twisted pair). The load impedance is to be 3-7 kilo-ohm that enables to induce disturbing pulses into the cables even from relatively soft supplies. Terminal equipments have to have the same potentials of the neutral. For this reason, RS-232 interface range is limited to 15m distance. RS-485 interface signals transmission allows increase communication range, communication partners' number and transmission interference immunity.

### 1.1 Use of the converter

The converter increases transmission immunity against electrical disturbance and isolates both interfaces RS-232/RS-485. Insulation strength is 3 kV. As for permissible over-voltage, the converter can be used in the environments where lightning over-voltage is not necessary to be considered. To lead the cable outside buildings, it is necessary to provide additional over-voltage protection on the input points.

The converter allows transmission rate up to 115200 bps. This maximum attainable rate decreases due to the line length and/or its impedance growth. Recommended maximum line length is 1200m at the rate of 9600 bps.

## 2.0 Operation principles

RS-485 interface is used to communication in one pair of the cable. For this reason, the transmission has to be half-duplex that means switching off RS-485 transmitter when receiving to allow transmitting to other communication partners and switching on during its own transmitting only.

There are two methods how to operate the transmitter:

- 1) The terminal equipment (DTE) changes RTS signal from the "OFF" state (negative polarity) to the "ON" state (positive polarity). When transmitting is finished it changes RTS signal back to "OFF".
- 2) The converter interprets the TxD signal. If there is the TxD in the idle mode the converter keeps the transmitter in the off-state. The DTE is just listening to the RS-485 link traffic. The converter activates the link transmitter **automatically** at the moment when the DTE starts transmitting and so TxD switches from the idle mode to the start-bit polarity (from the negative to positive polarity). The transmitter is ON for the time  $\tau$  that is needed to transmit one byte (plus 20% reserve).

**The transmitter is switched off automatically** if TxD stays in the positive polarity for the time  $\tau$ . The time interval is related to the transmission rate and has

to be set before the converter is installed in the application. Among data of the same polarity as the start-bit is, the converter does not distinguish the start-bit from the other bits. Consequently such cases can occur in operation when the last bit before the stop-bit is of that polarity and the  $\tau$  interval starts just from this bit. The converter keeps its transmitter ON for the time  $\tau$  after TE stopped data transmitting. Other communication partners on the RS-485 link have to respect this time. They have to wait for at least time  $\tau$  from the last byte recorded on the RS-485 bus before they start transmitting.

### 3.0 Installation

The converter has to be installed with the respect for specifications of both interfaces.

#### 3.1 Converter connection to RS-232 Interface

##### Important cautions:

**DTE and converter interconnection has to transmit at least TxD, RxD and GND signals, with TxD active so supply voltage of at least -5 V in the idle mode.**

**The converter will not work if the terminal equipment is designed similarly it means that its transmitter is turned off to save and turns on when it finds out the voltage on the RxD contact.**

Signals assignment to the contacts and DTE - DCE interconnection is in the following table:

Signal name	abbrev	DTE connector (DB25M)	E069connector (DB25F)	trans.direction	
				DTE	E069
Signal Ground	SG	7	7	--	--
Transmitted Data	TxD	2	2	output	input
Received Data	RxD	3	3	input	output
Request To Send	RTS	4	4	output	input
Clear To Send	CTS	5	5	input	output
Data Set Ready	DSR	6	6	input	output
Data Terminal Ready	DTR	20	20	output	input
Data Carrier Detect	DCD	8	8	input	output

The ELO E069 transmits RxD and TxD signals only. Control signals are not transmitted. The converter contains the RTS-CTS and DTR-DSR-DCD local interconnectors. The DTR has to be “ON” (positive polarity).

### 3.2 RS-485 link connection

The connector DB25M (Male) is used to the link connection. Single DTE can be interconnected via bus (see Fig.) up to 32 partners. The RS-485 interface connector

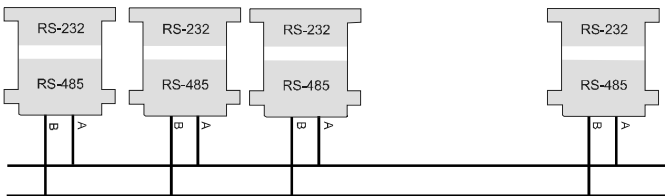

description and the way of passive and active terminator connection(resistors values of the active terminator have to be calculated with

reference to the applied values of passive terminators so that the passive terminator voltage drop was 200mV):

contact	1	2	5-8,13	24	25	9	10	11	
signal	B	A	GND	5V	6V	rate	$\tau 1$	$\tau 2$	$\tau 3$
passive terminator						4 800	open contacts		
active terminator						9 600			
					power supply	19 200	39k		
						115 200			

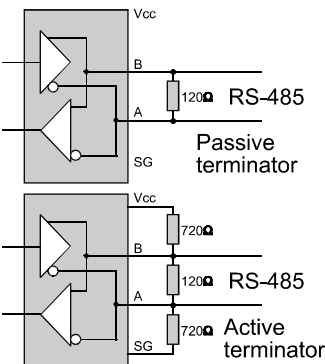

The RS-485 line should be terminated with the 100-120  $\Omega$  resistors on both ends placed between A - B conductors (so-called passive terminators). These terminators are used for the converter impedance matching, undesirable echo suppression and they influence transfer immunity against interference. There are also the active terminators beside the passive ones. Only one active terminator can be installed to one metallic section of the link and its role is as follows:

The RS-485 signal is symmetric. The differential receiver interprets the difference  $U_A-U_B$ . It does not

depend on the neutral potential. The receiver interprets the obtained signal  $|U_A - U_B| > 200 \text{ mV}$  as log. 1 or log. 0. In addition to these levels the third state can occur, it is so-called IDLE state. No transmitter is activated, each communicating partner is just listening so  $|U_A - U_B| < 200 \text{ mV}$ . The problem is how to interpret the third state in the two-state logic. The active terminator gives the signal into the IDLE state line and it is interpreted as IDLE in the two-state logic.

### **Important!**

**ELO E069, 2003 version, does not require the active terminator applying!**  
The converter circuits ensure the third state proper interpretation automatically

The influence of the ground potentials on the route should be considered because the RS-485 line length can be up to 1200m. To eliminate this influence, each device is earthed on the neutral or the third conductor is used (see Fig.). C. 100  $\Omega$  resistors are needed in this case to eliminate currents resulting from the ground potentials differences.

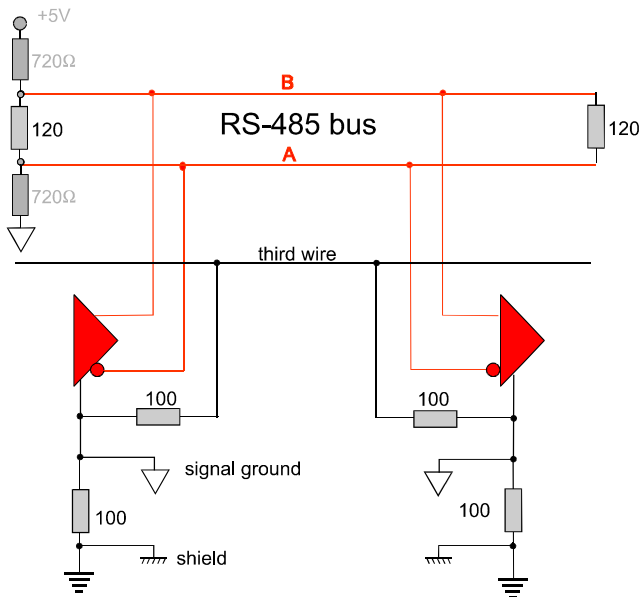

### 3.3 Converter setting

To work properly, the converter needs time out setting  $\tau$  which is performed by 9, 10, 11 contacts jumpers of the RS-485 connector.

Rate bps	Contacts
4 800	9, 10, 11 uncoupled
9 600	9 and 11 coupled, 2 uncoupled
19 200	10 and 11 interconnected via 39 kOhm resistor, 9 uncoupled
38 400	10 and 11 interconnected via 20 kOhm resistor, 9 uncoupled
115 200	10 and 11 coupled, 9 uncoupled

This is a basic, general setting. The time constant  $\tau$ , different from used communication rate (shorter usually), can be applied in certain cases. This setting has to be defined empirically.

### 3.4 Power Supply Connection

The converter needs external power supply 6V/200 mA that is connected to the converter side connector. The positive terminal is brought to the central contact of the supply connector. The power supply can also be connected via contacts 25 (positive terminal) and 13 (negative terminal) of RS-485 connector. The converter can be ordered with the supply connector SCJ 2.5mm /Jack mono) or DC connector EIAJ 2.35mm.

## 4.0 Specifications

### 4.1 Electrical parameters

Interface	RS-232/RS-485
Transmitted signals	TxD and RxD
Control signals	local interconnectors RTS-CTS DTR-DSR-DCD
RS-232 connector	DB25F, DCE
Transmission mode	half-duplex
Power supply	external DC supply 6V/200mA
Supply connector	SCJ 2.5mm or EIAJ 2.35mm
Isolation voltage between interfaces	3 kV
Permissible over-voltage on the line under ČSN 33 0420:	the line must not be exposed to the atmospheric discharge influences

Required link impedance	100Ω
Signals take off:	
TxD, (DTR, RTS) summarily	max. 10mA, typically 5mA

## 4.2 Other

Range without repeaters	1200m two-wired line
Maximum data rate	115 200 bps
Minimum data rate	4 800
Dimension: width x length x height	57 x 83 x 24 mm
Weight	80 g
Stocking temperature	- 10° to +55° C
Working temperature	+ 0° to +50° C
Humidity	0 – 85% (non-condensing)

## 5.0 Testing

When the power supply is switched on, connect the positive terminal to the 2 contact and the negative terminal to the 7 contact of the DC power supply of 5 to 9 V on the RS-232 connector. The voltage of c. 3V has to be on the 1-2 contacts of the RS-485 connector and the LED OUT has to light. After reversing polarity of 2-7 contacts, 1-2 output voltage has to be of the opposite polarity and the indicator turns off.

## 6.0 Troubleshooting

Symptom	Action
Converter does not work after installation	<p>Check if the link is connected properly (LED blink) if 1-2 contacts are not changed.</p> <p>Check if the time constant <math>\tau</math> selection is right.</p> <p>Check the power supply.</p> <p>Check RS-232 connection.</p>
Connection in normal operation quit working	<p>Check the power supply.</p> <p>Check the cable connection..</p> <p>Use the test as with 5.0</p>

## **7.0 Ordering information**

Supply code is ELO E069.

**E069a** - the converter with the supply connector **SCJ 2.5mm** (Jack mono),

**E069b** - the converter with the supply connector **EIAJ 2.35mm**

## **Note**

---

