

**USB - RS232 communication adapter
- virtual serial port - FTDI chipset
without galvanic isolation
ELO E360**



Characteristics

- Miniature, without external supply
- Connectors DB9M, USB A
- Transmitted signals TxD, DTR, RTS,
- Received signals RxD, DSR, CTS, DCD, RI
- USB chip set – FTDI
- Available for PDA too
- Drivers Win 98/Me/2000/XP/Vista/Mobile5/6

ELO E360 can work without an external supply. All the energy for E360 is taken from USB interface.

Adapter ELO E360 disposes of Auto shutdown function. – if the RxD signal isn't present, the power take from USB port goes down.

Block diagram

Introduction

The USB interface is preferred to the COM port with RS232 interface in personal computer technology. To connect the peripheral devices of the RS232 interface, the USB/RS232 adapters along with the driver are applied to create so-called virtual COM on the PC or PDA. Application running on PC (PDA) can communicate with a peripheral device through this virtual COM.

All electronic circuits of the adapter E360 is closed into RS-232 connector case.

The adapter allows connection between RS232 device and PC with USB interface. ELO E360 doesn't dispose of galvanic isolation between both interfaces.

The E360 adapter may be applied on the PC computers under the MS Windows 98/Me/2000/XP or Vista operating systems or in PDA technology (Mobile 5/6).

The adapter allows the transmission rate up to 230 kbps.

Operation principles

The adapter ELO E360 converts the signals between RS232 interface and USB. All the RS232 signals: TxD, RxD, RTS, CTS, DTR, DSR, DCD and RI are present on RS232 connector DB9 M. The transmission is duplex.

There are drivers to interconnect a virtual COM port and USB interface. If they were installed properly, the LED READY has to light up

The transferred data TxD and RxD are indicated too.

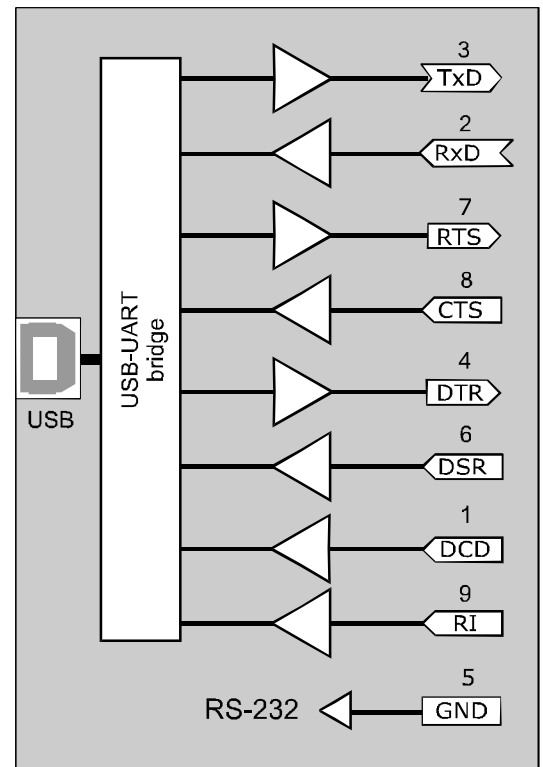

for 1sec

Specification

Electrical parameters

USB interface	2.0 full-speed (12Mb/s)
USB connector	A type
RS232 interface	transferred signals TxD, RxD RTS, CTS, DTR, DSR, DCD and RI
RS232 connector	DB9M - DTE
Maximum data rate	230 400 bps
Communication mode	full duplex
	plus control and status signals
Isolation USB/RS232	none

Other

Supply	from USB interface
Power take-off	to 50 mA
Indicators	READY-red, TxD-red, RxD-green
Cable length	circa 1.8 m
Weight	circa 20 g
Stocking temperature	- 10° to +55 °C
Working temperature	+ 0° to +50 °C
Humidity	0 – 85% (non-condensing)