

RS-232/422 Converter with Galvanic Isolation of the Interfaces

ELO E0CE



Characteristics

- Al case for DIN rail
- Maximum data rate 115.2 kbps
- Isolated interfaces
- RxD, TxD transfer
- 9-24V DC supply necessary

Introduction

RS-232 interface with asymmetric signals is designed for two terminal equipments connection (DTE). Maximum load capacity can be 2500 pF (about 50m twisted pair). The load impedance is to be 3-7 kilohm that allows disturbing pulses induction into the cables even from relatively soft supplies. Terminal equipments have to have the same potentials of the neutral, for this reason, RS-232 interface range is limited to 15 m distance.

RS-422 interface is distinguished by the range of hundreds of meters, spanning 1200 m distance at the rate of 9600 bps. 10 Mbps can be reached at very short distances (cm-dm). RS-232 to RS-422 interface signals transmission allows communication range and transmission interference immunity to be increased.

Use of the converter

The converter increases transmission immunity against electrical disturbance and isolates both interfaces RS-232 /RS-422. Insulation strength is 3 kV. As for permissible over-voltage the converter can be used in the environments where lightning over-voltage is not necessary to be considered. To lead the cable outside buildings, it is necessary to provide additional over-voltage protection on the input points.

The converter allows transmission rate to 115200 bps. This maximum attainable rate decreases due to the line length and its impedance growth. Recommended maximum line length is 1200 m at rate of 9600 bps.

Specifications

Electrical parameters

Transmitted signals – E0CE	TxD and RxD
Control signals	interconnected locally RTS-CTS DTR-DSR
Power supply	Ext. DC supply 9-24V/200 mA
Isolation voltage between interfaces	max. 3 kV for 1 s
Power take off from the signal TxD, RTS	max. 5 mA typically 3 mA
Permissible over-voltage on the line	the line must not be exposed to the atmospheric discharge influences
Required link impedance	100Ω

Operation principles

RS-422 interface is mainly designed for two devices communication in duplex mode. As transmission media there is a twisted pair, each pair for one transmitted signal. ELO E0CE converter transmits two signals (TxD, RxD), for duplex transmission two pairs are needed.

RS-422 interface signal is symmetric and interprets potential difference of both conductors $U_A - U_B$. If the signal $|U_A - U_B| > 200 \text{ mV}$ the receiver interprets it as log 1 or log 0. Signal parameters according to RS-422 are consistent with RS-485 standard except for switching off the transmitter when $|U_A - U_B| < 200 \text{ mV}$ state can occur in the line.

Block diagram

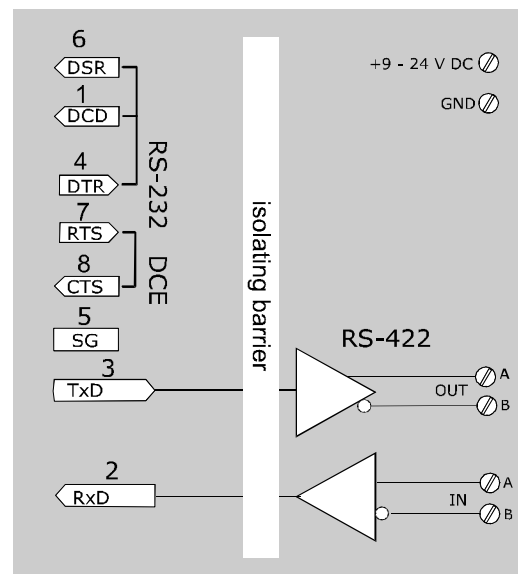

Other

RS-232 connector type and connection	DB9 female, DCE
Range without repeaters	1200 m
Transmission mode E0CE	duplex, two twisted pairs
Maximum data rate	115 200 bps
Minimum data rate	50 bps
Dimensions for DIN bar (length/width)	110 / 55mm
Covered construction height	24 mm
Weight	145 g
Stocking temperature	- 10° to +55° C
Working temperature	+ 0° to +50° C
Humidity	0 – 85% (non-condensing)