

# RS-232/422 Converter with Galvanic Isolation of the Interface ELO E0CC



## Characteristics

- Isolated interfaces
- RxD, TxD transfer
- Maximum data rate 115.2 kbps
- 6V DC supply necessary

## Introduction

RS-232 is the interface with asymmetric signals designed for two terminal equipments (DTE) connection. Maximum load capacity can be 2500 pF (about 50m twisted pair). The load impedance is to be 3-7 kilohm that allows disturbing pulses induction into the cable even from relatively soft supplies. The terminal equipments have to have the same signal ground potentials therefore RS-232 interface range is limited to 15m distance. Signals conversion to RS-422 allows transmitted range and interference immunity to be increased.

## Use of the converter

The converter increases transmission immunity against electrical disturbance and isolates both interfaces RS-232 / RS-422. ELO E0CC model insulation strength is 3 kV. As for permissible over-voltage, the converter can be used in the environments where lightning over-voltage is not necessary to be considered. To lead the cable outside buildings, it is necessary to provide additional over-voltage protection on the input points. The converter allows transmission rate up to 115200 bps. This maximum attainable rate decreases due to the line length or its impedance growth. Recommended maximum line length is 1200 m at rate of 9600 bps.

## Operation principles

RS-422 interface is mainly contented for two devices communication in duplex mode. As transmission media there are two twisted pairs, each for one transmission direction.

RS-422 signal is symmetric and its parameters are consistent with the signal standard RS-485. The signal under standard RS-422 does not recognize high impedance mode (third state) which allows the bus construction in standard RS-485. There are also RS-422 modifications so-called MULTIDROP systems they are duplex and transmitters are set off into the third state but ELO E0CC converter does not allow this option.

## Block diagram

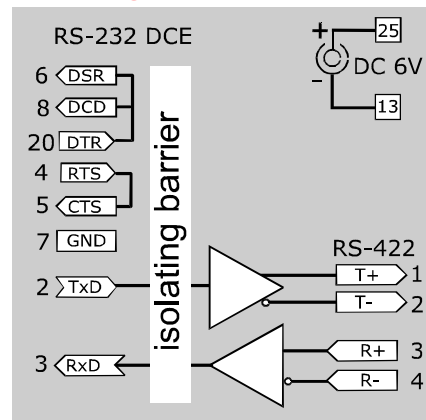

## Specifications

### Electrical parameters

Interface	RS-232 / RS-422
Power supply	External DC supply 6V/200mA
Supply connector	SCJ 2.5 mm or EIAJ 2.35mm
Signals TxD, (DTR, RTS) take off:	summarily max. 10 mA typically 5 mA
Isolation voltage between interfaces	max. 3 kV permanently
Required link impedance	100 Ω
Matching to the line	external terminators 100 – 200 Ω
Permissible over-voltage on the line	the line must not be exposed to the atmospheric discharge influences

### Other

Transmitted signals	TxD, RxD
Control signals	local interconnectors RTS-CTS

### DTR-DSR-DCD

RS-232 connector	DB25F, DCE
Transmission mode	duplex on 4-wire link simplex on 2-wire link

Maximum RS-232 signals configuration  
of DTE for duplex operation: TxD; RxD; GND

Minimum RS-232 signals configuration  
of DTE for simplex operation: TxD; GND, when  
transmitting,

RxD, GND+ at least one from TxD,  
RTS, DTR signals

Range without repeaters	1200 m
Data rate	50 – 115 200 bps
Dimension width× length× height	57 × 83 × 24 mm
Weight	80 g
Stocking temperature	-10° to +55°C
Working temperature	+ 0° to +50°C
Humidity	0 – 85% (non-condensing)