

Miniature RS-232/485 Converter with Automatic Transmission Control and Galvanic Isolation of the Interface ELO E06D

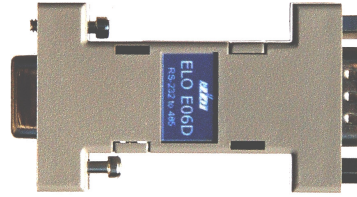

Characteristics

- Galvanic isolation of interfaces
- Automatic control
- TxD, RxD transferring
- Maximum data rate 115.2 kbps
- DC 6V external supply is mostly necessary

Introduction

RS-232 interface with asymmetric signals is designed for two terminal equipments connection (DTE). Maximum load capacity can be 2500 pF (about 50 m twisted pair). The load impedance is to be 3-7 kilohm that allows induce disturbing pulses into the cables even from relatively soft supplies. Terminal equipments have to have the same potentials of the neutral, for this reason, RS-232 interface range is limited to 15m distance. RS-485 interface signals transmission enables to increase communication range, communication partners' number and transmission interference immunity.

Use of the converter

The converter increases transmission immunity against electrical disturbance and isolates both interfaces RS-232 /RS-485. Insulation strength is 1 kV. As for permissible over-voltage, the converter can be used in the environments where lightning over-voltage is not necessary to be considered. To lead the cable outside buildings, it is necessary to provide additional over-voltage protection on the input points.

The converter allows transmission rate up to 115200 bps. This maximum attainable rate decreases due to the line length and/or its impedance growth. Recommended maximum line length is 1200 m at the rate of 9600 bps.

Operation principles

RS-485 interface is used to communication in one pair of the cable. For this reason, the transmission has to be half-duplex that means switching off RS-485 transmitter when receiving to allow transmitting to other communication partners and switching on during its own transmitting only.

The converter ignores RTS signal from the terminal equipment (DTE) and interprets TxD signal state. At the TxD changing moment from the idle state (from negative to positive polarity), the converter activates the link transmitter **automatically**.

The transmitter is switched off after the certain time τ of TxD return to the neutral polarity. Time interval length τ has to be matched to applied transmission rate because in the automatic mode there it is necessary to keep the transmitter active for the period equal to one byte transmission time. One important communication protocol request is necessary to observe: a device that is to transmit has to wait at least for the time τ from the last byte recorded on RS-485 clamps. If it is to the contrary, the first transmitted byte would be damaged.

Block diagram

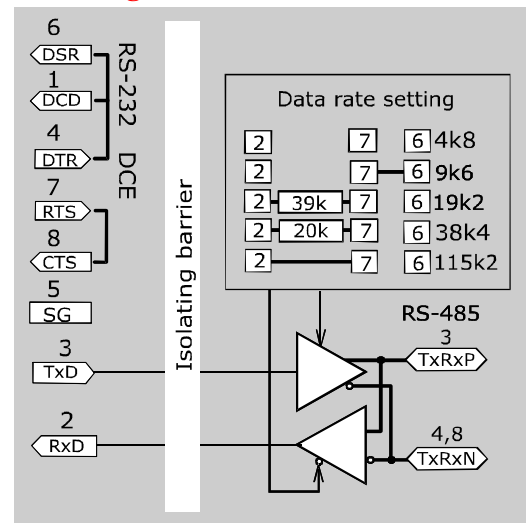

Specifications

Electrical parameters

Interface	RS-232/RS-485
Transmitted signals	TxD and RxD
Control signals	local interconnects RTS-CTS DTR-DSR
RS-232 connector	DB9F, DCE
Trasmission mode	half-duplex
Power supply	external DC supply 6V/200mA
Isolation voltage between interfaces	1 kV
Permissible over-voltage on the line	the line must not be exposed to the atmospheric discharge influences

Required link impedance

100Ω

Other

Range without repeaters	1200m, double-wire link
Maximum data rate	115 200 bps
Minimum data rate	1 200 bps
Dimension: width x length x height	34 x 63 x 17 mm
Weight	25 g
Stocking temperature	- 10° to +55° C
Working temperature	+ 0° to +50° C
Humidity	0 – 85% (non-condensing)