

# RS-232/485 Converter with Galvanic Isolation of the Interface ELO E06A



### Characteristics

- Isolation between interfaces
- Automatic control
- TxD, RxD transferring
- Maximum data rate 115.2 kbps
- DC 9-24V supply necessary

### Introduction

RS-232 is the interface with asymmetric signals designed for two terminal equipments connection (DTE). The load impedance is to be 3-7 kilohm that enables to induce disturbing pulses into the cable even from relatively soft supplies. Since the signals have to be symmetric, the terminal equipments have to have the same neutral potentials. For this reason, RS-232 interface range is limited to 15m distance. Signals conversion to RS-485 allows increase communication range, transmission interference immunity and communication partners' number.

### Use of the converter

The converter increases transmission immunity against electrical disturbance and isolates RS-232 interface from RS-485. Insulation strength is 3 kV. As for permissible over-voltage the converter is designed to be used in the environments where lightning over-voltage is not necessary to be considered. To lead the cable outside buildings it is necessary to provide additional over-voltage protection on the input points.

The converter allows transmission rate up to 115200 bps. This maximum attainable rate decreases due to the line length and/or its impedance growth. Recommended maximum line length is 1200 m at the rate of 9 600 bps.

### Operation principles

RS-485 interface is used to two-way simultaneous communication in one pair of conductors. For this reason, the transmission has to be half-duplex that means switching off RS-485 transmitter when receiving to allow transmitting to other communication partners and switching on only during its own transmitting.

There are two methods of transmitter switching:

- 1) The terminal equipment (DTE) changes RTS signal from the "OFF" state (negative polarity) to the "ON" state (positive polarity). When transmitting is finished it changes RTS signal back to "OFF".
- 2) DTE does not use RTS (this signal is not disposed by this interface or the application does not use it) and the converter has to interpret its signal TxD **automatically**. At the TxD changing moment from the idle state (from negative to positive polarity), the converter activates the link transmitter automatically.

**The transmitter is switched off after the certain time  $\tau$**  of RTS switching off or TxD return to the neutral polarity. Time interval length  $\tau$  has to be dependent on applied transmission rate because in the automatic mode there it is necessary to keep the transmitter active for the period equal to one byte transmission time. In the automatic mode, one important communication protocol request is necessary to observe: every device that is to transmit has to wait for at least the time  $\tau$  from the last byte recorded on the RS-485 bus. If it is to the contrary the first transmitted byte would be damaged.

### Block diagram

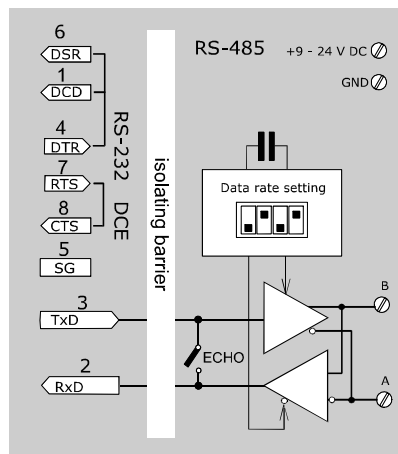

### Specifications

#### Electrical parameters

Interface	RS-232/RS-485
Transmitted signals	TxD and RxD
Control signals RS-232	interconnected locally RTS-CTS, DTR-DSR-DCD
RS-232 connector	DB9F, DCE
Transmission mode	half-duplex, simplex
Power supply	External DC supply 9-24V/200mA
Isolation voltage between interfaces	max. 3kV for 1 s
Permissible over-voltage on the line	the line must not be exposed to the

atmospheric discharge influences

Required link impedance	100Ω
Power take off from the signal TxD, RTS	typically 3mA

#### Other

Range without repeaters	1200 m
Maximum transmission rate	115 200 bps
Minimum data rate	1 200 bps
Dimension: width x length x height	55 x 100 x 24 mm
Weight	80 g
Stocking temperature	- 10° to +55° C
Working temperature	+ 0° to +50° C
Humidity	0 – 85% (non-condensing)