

RS-232/485 Converter with Automatic Transmission Control without Galvanic Isolation of the Interface

ELO E068



Characteristics

- Without galvanic isolation of interfaces
- Automatic control
- Transfers RxD and TxD
- 6V DC supply necessary

Introduction

RS-232 interface is designed for two terminal equipments connection (DTE). The load impedance is to be 3-7 kilohm that allows induce disturbing pulses into the cables even from relatively soft supplies. Since the signals have to be asymmetric, terminal equipments have to have the same potentials of the neutral. For this reason, RS-232 interface range is limited to 15 m distance. RS-485 interface signals transmission enables to increase communication range, transmission interference immunity and communication partners' number.

Use of the converter

The converter increases transmission immunity against electrical disturbance **but not against atmospheric electricity influences!** To lead the RS-485 cable outside buildings, it is necessary to provide additional over-voltage protection on the input points.

The converter allows transmission rate up to 115200 bps. This maximum attainable rate decreases due to the line length and/or its impedance growth. Recommended maximum line length is 1200 m at the rate of 9600 bps.

Operation principles

RS-485 interface is used to two-way simultaneous communication in one pair of conductors. For this reason, the transmission has to be half-duplex that means switching off RS-485 transmitter when receiving to allow transmitting to other communication partners and switching on during its own transmitting only. There are two methods how to operate the transmitter:

- 1) The terminal equipment (DTE) changes RTS signal from the "OFF" state (negative polarity) to the "ON"

- 2) DTE does not use RTS (this interface does not dispose this signal or SW does not use it) and the converter has to interpret its signal TxD **automatically**. At the TxD changing moment from idle state (from the negative to positive polarity), the converter activates the link transmitter automatically.

The transmitter is switched off after the certain time τ of RTS switching off or TxD return to the neutral polarity. Time interval length τ has to be dependent on applied transmission rate because in the automatic mode there it is necessary to keep the transmitter active for the period equal to one byte transmission time. In the automatic mode, one important communication protocol request is necessary to observe: every device that is to transmit has to wait at least for the time τ from the last byte recorded on RS-485 clamps. If it is to the contrary the first transmitted byte would be damaged

Block diagram

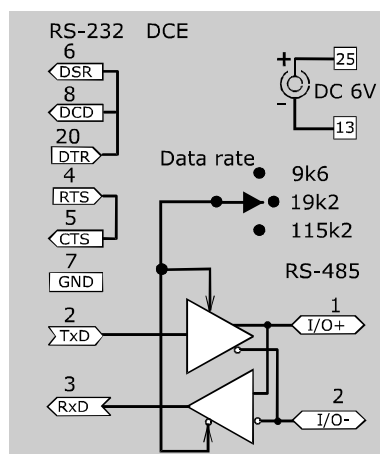

Specifications

Electrical parameters

Interface	RS-232/RS-422
Transmitted signals	TxD and RxD
Control signals	local interconnectors RTS-CTS DTR-DSR
RS-232 connector	DB25F, DCE
Transmission mode	half-duplex
Power supply	external DC supply 6V/200mA
Isolation betw. interfaces	without galvanic isolation
Permissible over-voltage on the line	the line must not be exposed to the atmospheric discharge influences

Required link impedance	100Ω
Signals take off: TxD, (DTR, RTS)	summarily max. 6mA typically 3mA

Other

Range	1200m, double-wire link
Maximum transmission rate	115 200 bps
Minimum rate	9 600 bps
Dimension: width x length x height	57 x 83 x 24 mm
Weight	80 g
Stocking temperature	- 10° to +55° C
Working temperature	+ 0° to +50° C
Humidity	0 – 85% (non-condensing)