

Pair of RS-232 / 20mA Interface Converters ELO E00H, ELO E00J



Characteristics

- Galvanic isolation of interfaces
- TxD, RxD transferring
- Maximum data rate 115.2 kbps
- Asymmetric current loop 20 mA
- 12V DC external supply is necessary

Introduction

The RS-232 interface (V.24) is a common equipment of the devices in the computer technology and automation. The interface is designed for the point-to-point connection at the distance of the order of units of meters. To use the current loop interface for the longer distances transmission is one of the options.

Use of the converter

Historically, the current loop is linked with the teletype technology that is why the TTY abbreviation (TeleTYpe) is often used to mark it. 50 bps was a typical rate of the

teletype transmitted data at the distance of the order of kilometers. Now it is used to the data transmission at the range of hundreds of meters at the rates of the order of kilobits per second.

Operation principles

TxD signal of the terminal equipment is isolated and emitted to the transmitting current loop. The rated current via the current loop conforms the TxD idle state (negative polarity), 0 mA current conforms the reversed TxD state. The 20mA current from the receiving loop is converted to the RxD signal. There is also the galvanic isolation between the loop and the RxD. The rated current via the receiving loop of 20mA equates the idle RxD state (negative polarity). Both loops are two-state and asymmetric.

Block diagram

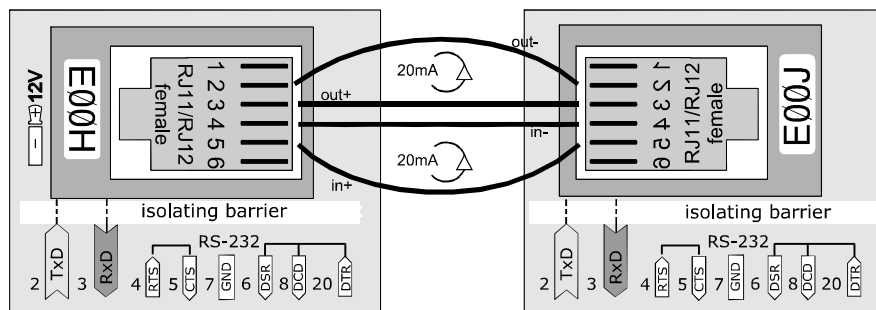

Specifications

Parameters

Transmitted signals	TxD and RxD
Control signals	are not transmitted
Locally interconnected signals	RTS-CTS DTR-DSR-DCD
RS-232 interface type and connection	DB25F, DCE
Transmission mode	duplex, four-wire line simplex, two-wire line
Minimum RS-232 signals of DTE for duplex	TxD, RxD, GND
Minimum RS-232 signals of DTE for simplex transmitting	TxD, GND
receiving only	RxD, GND and DTR or RTS
Maximum data rate	115 200 bps
Minimum data rate	50 bps
Maximum link resistance to be spanned	400 Ω with 24V supply

Supply	external DC supply of 9-24V/50mA (necessary for E00H only)
Isolation voltage between interfaces	max. 3kV for 1 sec
Power take-off from TxD, DTR, RTS signals	max.10mA summarily 5mA typically
Transmitting loop current (log.0 / 1)	20±3mA / 0-1mA
Current via receiver (log.0 / log.1)	4-25mA / 0-4mA
Permissible over-voltage on the line	the line must not be exposed to the atmospheric discharge influences impulses of 1ms width and input of up to 600VA

Other

Stocking temperature	- 10° to +50° C
Working temperature	+ 5° to +50° C